

Analysis of the Influence of Sunlight Radiation on the Output Power of Monocrystalline Full Cell, Half-Cut Cell, and Shingled Cell Solar Panels

Ita Ayu Purnawati, I Nyoman Satya Kumara, Wayan Gede Ariastina

Universitas Udayana, Indonesia

Email: atiuya@gmail.com, satya.kumara@unud.ac.id, w.ariastina@unud.ac.id

ABSTRACT

Indonesia has a huge potential for solar energy, but its utilization until 2024 only reach 573.8 MWp. The low utilization of solar energy is caused by the limited vacant land for solar power plant installations, especially in urban areas. Rooftop solar power plants are expected to increase the use of solar energy in urban areas. Choosing the right solar panels on rooftop solar is necessary to get the best performing solar panels even though they are placed on limited land. The development of cell arrangement and shape technology in solar panels has resulted in full cell, half-cut cell, and shingled cell solar panels. The weather parameter observed in this study is sunlight radiation. Direct observation was carried out for 4 days at 08.00-16.00 WIB in the Kediri Meteorological Station (BMKG Kediri), with data collection every 5 minutes. The results of the study show that sunlight radiation has a significant influence on the output power of solar panels. The determination coefficient (R^2) value of sunlight radiation against solar panels is 0.60 in monocrystalline full cells, 0.65 in monocrystalline half-cut cells, and 0.66 in monocrystalline shingled cells

Keywords: solar energy; rooftop solar power plant; solar panel performance

This article is licensed under [CC BY-SA 4.0](https://creativecommons.org/licenses/by-sa/4.0/) 

INTRODUCTION

Indonesia is geographically located along the equator, so it has great solar energy potential. The potential for solar energy in Indonesia is 3,294.36 GWp, but currently, it has only been utilized at 573.8 MWp (Directorate General of New Renewable Energy and Energy Conservation of the Ministry of Energy and Mineral Resources, 2024; Yuen, 2024). One of the causes of the lack of optimal use of solar energy in Indonesia is related to open land use permits. The construction of a Solar Power Plant (PLTS) requires a very large open land area; this certainly presents a challenge, especially in urban areas. Rooftop solar power is a solution to utilize solar energy in densely populated urban areas with limited open land (Energysage, 2025). Rooftop solar does not require vacant open land, but the correct solar panel selection is needed to achieve maximum solar energy yield.

Along with technological advancement, solar panel technology continues to be developed to obtain maximum performance. Monocrystalline solar panels are among the most widely available types on the market today due to their high efficiency and compact design (Al-Ali, 2025; CleanEnergyReviews, 2025). In its development, monocrystalline solar panels are divided into several types according to the shape and method of photovoltaic (PV) cell arrangement, namely, full cell, half-cut cells, and overlapping/shingled cells (Solarmagazine, 2022; Wikipedia, 2025).

The performance of these different PV technologies varies under partial shading conditions. Shingled cell panels, for example, have been found to outperform traditional full-cell

Analysis of the Influence of Sunlight Radiation on the Output Power of Monocrystalline Full Cell, Half-Cut Cell, and Shingled Cell Solar Panels

panels when shading occurs, as they reduce energy loss and hot-spot formation (Klasen et al., 2021). Half-cut cells, on the other hand, show reduced resistive losses and improved performance in shaded conditions compared to full-cell modules (Brecl et al., 2021).

In addition to technology, the performance of solar panels is also influenced by weather parameters, one of which is solar radiation. High levels of solar radiation will result in high output power. However, some solar panels with the latest technology can produce optimal power output even when solar radiation is low (Kumari et al., 2024; Islam et al., 2024). For instance, studies show that mono PERC and advanced monocrystalline modules with half-cut or shingled design maintain higher performance in diffuse radiation or partially shaded conditions (Ravindra, 2017).

Thus, to maximize solar energy harvesting in Indonesia especially in urban environments where space is limited choosing the appropriate solar panel technology is essential. Shingled and half-cut monocrystalline modules offer promising solutions for rooftop installations with enhanced performance in varied lighting conditions (Al-Ali et al., 2023).

Literature Review

a. Solar Panels

Solar panels are equipment used to convert sunlight energy into electrical energy by utilizing the *photovoltaic effect*. In their development, solar panels are divided into several types, namely full cell, half-cut cell, and shingled cell types. The characteristics of each solar panel are shown in Table I.

Table 1. Characteristics of Solar Panels

Kind	Characteristics
<i>Full cell</i>	<ol style="list-style-type: none">1. Normal cell size and module size is quite large2. Non-effective space is wide enough between cells3. Has a hotspot effect when exposed to partial shadow4. Lowest performance compared to other types
<i>Half-cut cell</i>	<ol style="list-style-type: none">1. <i>The cell</i> is cut into 2 parts so that the <i>size of the cell</i> and module is smaller than the <i>full cell type</i>2. The number of <i>cells</i> in the module is twice that of the <i>full cell type</i>3. Not susceptible to <i>hotspot effects</i> when exposed to partial shadows4. Better performance than <i>full cell types</i>
<i>Shingled cell</i>	<ol style="list-style-type: none">1. <i>The cells</i> are thin strips and arranged in an overlapping manner2. The non-effective space between cells is smaller, with some even having no non-effective space.3. Not susceptible to <i>hotspot effects</i> when exposed to partial shadows4. Better performance than <i>full cell types</i>

b. Sunlight Radiation

Sunlight radiation is an energy emission that originates from thermonuclear processes occurring in the sun (Siregar, et al., 2021). Sunlight radiation reaches the earth in the form of *electromagnetic waves*. The spectrum of sunlight radiation consists of *ultraviolet (UV)*, *infrared (IR)*, and visible light, as shown in Figure 1.

Analysis of the Influence of Sunlight Radiation on the Output Power of Monocrystalline Full Cell, Half-Cut Cell, and Shingled Cell Solar Panels

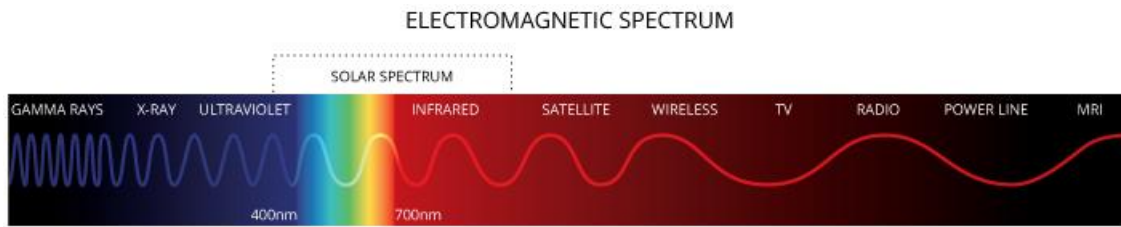

Figure 1. Electromagnetic wave spectrum

The sunlight radiation that reaches the earth varies according to the atmospheric conditions at that time. The processes that often occur when sunlight radiation reaches the earth are *scattering* and *absorption*. *Scattering* is caused by the interaction of sunlight radiation with molecules, water, and dust particles in the air, causing the sun's radiation rays to blend. Meanwhile, *absorption* occurs after the interaction of sunlight radiation with certain molecules, such as ozone, water vapor, and carbon dioxide, thereby reducing the amount of sunlight radiation that reaches the earth.

Sunlight radiation is the most determining parameter for the overall performance of solar panels (Qasim and Atyia, 2023). Figure 2(a) shows that the higher the value of sunlight radiation, the higher the current that will flow; this also affects the output power of the solar panel, as shown in Figure 2(b).

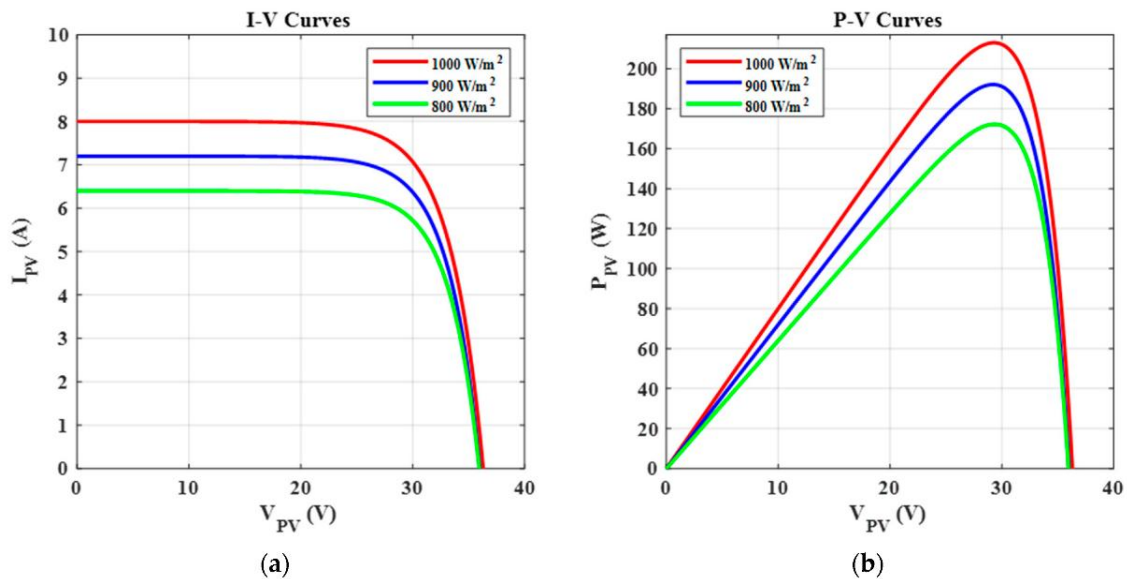

Figure 2. I-V curve and P-V curve solar panel with different sunlight radiation

METHOD

a. Research Location and Time

Analysis of the Influence of Sunlight Radiation on the Output Power of Monocrystalline Full Cell, Half-Cut Cell, and Shingled Cell Solar Panels

The research was conducted from June 30, 2025, to July 3, 2025, at 08.00–16.00 *WIB*. The research location was at the *Dhoho Meteorological Station*, Kediri, East Java.

b. Research Equipment

The equipment used in this study is shown in Table 2 and assembled into a system as illustrated in Figure 3. Sunlight radiation data is obtained from a *pyranometer* sensor installed on the *AWOS (Automated Weather Observing System)*.

Table 2. Research Equipment

No	Research Equipment	Qty
1	<i>Monocrystalline full cell 100 W</i>	1 unit
2	<i>Monocrystalline half-cut cell 100 W</i>	1 unit
3	<i>Monocrystalline shingled cell 100 W</i>	1 unit
4	<i>Power watt meter</i>	3 units
5	<i>Solar charge controller</i>	3 units
6	12V 50AH Battery	3 units
7	100 W DC Lamp	3 units
8	<i>Automated Weather Observing System (AWOS)</i>	1 unit

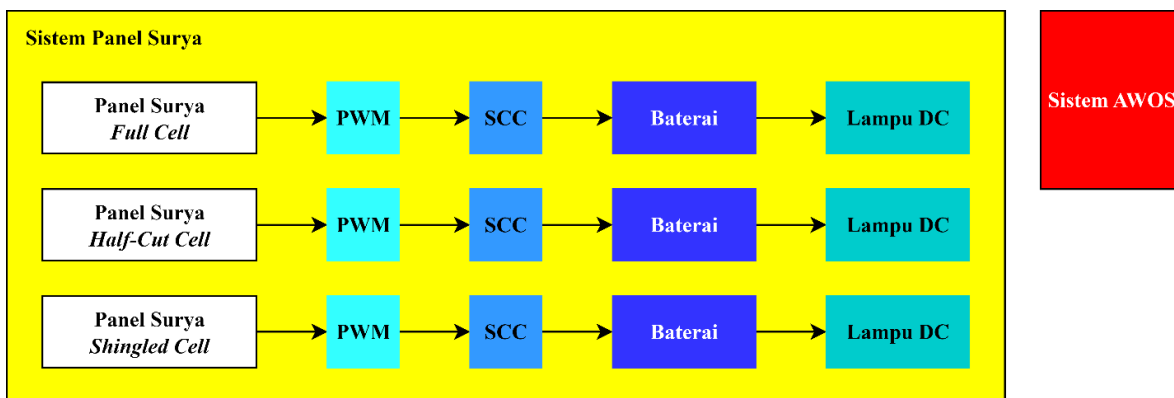

Figure 3. Solar Panel System

c. Data Collection

The collection of solar panel system output power data is carried out directly every 5 minutes, while the collection of sunlight radiation data is conducted daily at 16.00 by downloading the data from the server.

Analysis of the Influence of Sunlight Radiation on the Output Power of Monocrystalline Full Cell, Half-Cut Cell, and Shingled Cell Solar Panels

d. Data Analysis

The data analysis in this study used a simple linear regression method, where the independent variable is solar radiation and the dependent variable is the output power in *monocrystalline full cell*, *monocrystalline half-cut cell*, and *monocrystalline shingled cell* solar panels. The equation for simple linear regression is shown below.

$$Y = \beta_0 + \beta_1 X + \varepsilon$$

Information:

Y : Dependent variable

X : Independent variable

β_0 : Constanta

β : Regression coefficient

ε : The difference between the actual value of and the value predicted by the model Y

The evaluation of the results of simple linear regression can be determined from the value of the coefficient of determination, or R^2 (*R-squared*). The coefficient of determination measures how much variation in the independent variable can be explained by the regression model (Iba and Wardhana, 2024). The value of the coefficient of determination ranges from 0 to 1. The value of the coefficient of determination is calculated according to the equation below.

$$KD = r^2 \times 100$$

Information:

KD : Value of the determination coefficient

r^2 : The value of the correlation coefficient between the independent variable and the bound variable

Hair et al. (2010) interpret the values of R^2 and *adjusted* R^2 into several categories as shown in table 3

Table 3. Interpretation of the value of R^2

R2 Value	Interpretation Categories
< 0.25	Very Weak / None
0.25 ≤ 0.50	Weak
0.50 ≤ 0.75	Moderate
≥ 0.75	Strong / Substantial

Research Results

The sunlight radiation in this study was at a value of 60.87-1017.43 W/m² with an average solar radiation of 420.69 W/m². The data of observations per day is shown in table 4.

Analysis of the Influence of Sunlight Radiation on the Output Power of Monocrystalline Full Cell, Half-Cut Cell, and Shingled Cell Solar Panels

Table 4. Average Solar Radiation and Average Solar Panel Output Power

Date	Time	Sunlight Radiation (W/m ²)	Output Power (W)		
			FC	HC	SC
30 June 2025	08.00-12.00	374,15	16,78	28,63	28,92
1 July 2025	08.00-12.00	484,28	17,89	32,89	31,24
2 July 2025	08.00-12.00	528,61	24,74	43,15	40,95
3 July 2025	08.00-12.00	395,51	15,89	27,43	26,17

The correlation between sunlight radiation and the output power of *monocrystalline* solar panels is shown in table 5.

Table 5. Correlation value of sunlight radiation and *monocrystalline* output power

Model	R	R2	Std. Error of the Estimate	Information
FC	0,780a	0,609	137,71419	Moderate correlation
HC	0,807a	0,650	130,14241	Moderate correlation
SC	0,813a	0,661	128,13523	Moderate correlation

Graphically, the correlation between sunlight radiation and solar panel output power is shown in figure 4.

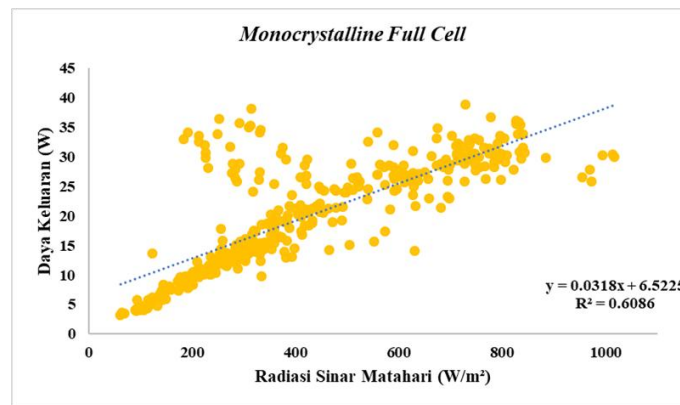

Analysis of the Influence of Sunlight Radiation on the Output Power of Monocrystalline Full Cell, Half-Cut Cell, and Shingled Cell Solar Panels

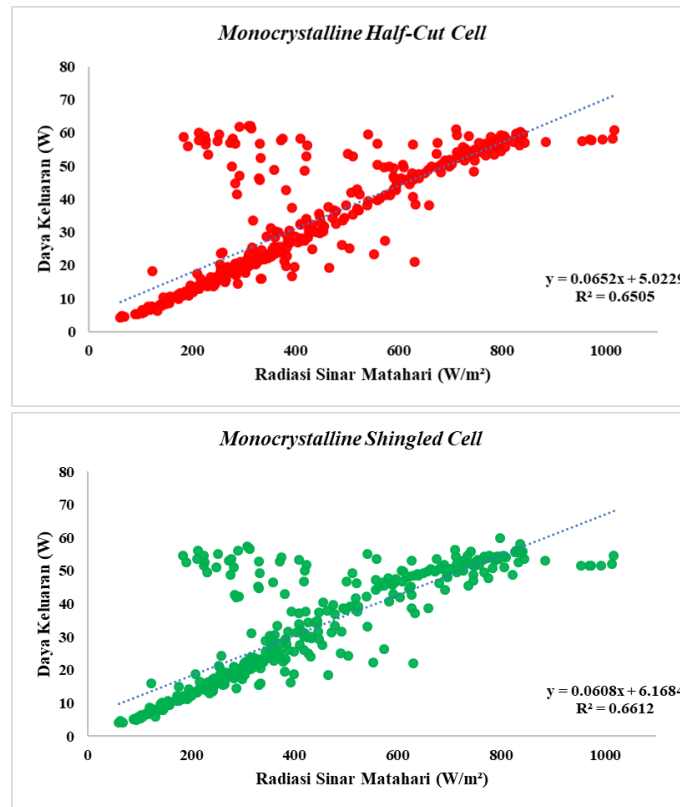

Figure 4. Graph of the correlation between sunlight radiation to solar panel output power

Based on table 4, monocrystalline shingled cell solar panels are able to provide the highest output power during cloudy weather and low sunlight radiation values, this is due to the overlapping cell arrangement of monocrystalline shingled cell solar panel modules, able to reduce the effect of hotspots due to partial shadows, and able to provide maximum output power even though sunlight is in the diffuse category. Meanwhile, when the weather is sunny and the radiation value of sunlight is high, monocrystalline half-cut cell solar panels have the highest output power. This is caused by the cell being cut into two parts which causes the current flowing through the cell to be reduced, so that the power loss on the half-cut monocrystalline solar panel is smaller. Based on the determination coefficient value, sunlight radiation has a moderate correlation with the output power of monocrystalline full cell, monocrystalline half-cut cell, and monocrystalline shingled cell solar panels.

CONCLUSION

Sunlight radiation has a significant influence on the output power of *monocrystalline full cell*, *monocrystalline half-cut cell*, and *monocrystalline shingled cell* solar panels. The value of the coefficient of determination for sunlight radiation was 0.609 for *monocrystalline full cell* panels, 0.650 for *monocrystalline half-cut cell* panels, and 0.661 for *monocrystalline shingled cell* panels. The performance of *monocrystalline half-cut cell* solar panels is more optimal when the value of sunlight radiation is high, whereas the performance of *monocrystalline shingled cell* solar panels

Analysis of the Influence of Sunlight Radiation on the Output Power of Monocrystalline Full Cell, Half-Cut Cell, and Shingled Cell Solar Panels

is more optimal when the sunlight radiation is low. It is recommended that further research be conducted with a longer research duration to determine the characteristics of solar panel output power in relation to solar radiation more accurately.

BIBLIOGRAPHY

- Al-Ali, S. (2025). *A review of solar photovoltaic technologies: Developments in monocrystalline and module interconnection innovations*. ScienceDirect.
- Al-Ali, S., et al. (2023). *Photovoltaic cell interconnection innovations: Shingled vs half-cut vs full-cell in urban rooftop use* [Artikel teknis – akses melalui ScienceDirect].
- Brecl, K., et al. (2021). Annual energy losses due to partial shading in PV modules: Cut-cell vs full-cell design. *Renewable Energy*, 170.
- CleanEnergyReviews. (2025). *Most efficient solar panels 2025*. <https://www.cleanenergyreviews.info/blog/most-efficient-solar-panels>
- Directorate General of New Renewable Energy and Energy Conservation. (2024). *Energy transition in Indonesia: Programs, challenges, and support required*. Ministry of Energy and Mineral Resources.
- Directorate General of New Renewable Energy and Energy Conservation of the Ministry of Energy and Mineral Resources. (2024). *Statistik EBTKE 2024* [Sumber resmi pemerintah Indonesia].
- Energysage. (2025). *Which type of solar panel should you choose?* <https://www.energysage.com/solar/types-of-solar-panels/>
- Hair, J. F., Black, C. W., Babin, B. J., & Anderson, R. E. (2010). *Multivariate data analysis* (7th ed.). Pearson.
- Iba, Z., & Wardhana, A. (2024). *Regression analysis and path analysis for business research using SPSS 29.0 & Smart-PLS 4.0*. Eureka Media Aksara.
- Islam, M. I., Jadin, M. S., Ul Haq, M. A., & Al Mansur, A. (2024). Analysis of photovoltaic module degradation due to partial shading, hot spots, and EVA discoloration. *Renewable Energy*, 163, 2021–2030.
- Klasen, N., et al. (2021). Performance of shingled solar modules under partial shading. *Fraunhofer ISE / Energy Reports*.
- Kumari, N., Singh, S. K., Kumar, S., & Jadoun, V. K. (2024). Performance analysis of partially shaded high-efficiency mono PERC/monocrystalline PV module under indoor and environmental conditions. *Scientific Reports*, 14, 21587.
- Qasim, M. A., & Atyia, T. H. (2023). Evaluating the impact of weather conditions on the effectiveness and performance of PV solar systems and inverters. *NTU Journal for Renewable Energy*, 5(1), 34–46.
- Ravindra, B. (2017). Performance of a crystalline silicon photovoltaic power plant during sandstorms. *arXiv:1710.03790*. <https://arxiv.org/abs/1710.03790>

Analysis of the Influence of Sunlight Radiation on the Output Power of Monocrystalline Full Cell, Half-Cut Cell, and Shingled Cell Solar Panels

- Siregar, C. A., Affandi, Siregar, A. M., Daud, M., & Nasution, M. D. (2021). Mapping the potential of solar radiation in North Sumatra based on mathematical calculations. *SiNTESa*, 1, 72–78.
- Solarmagazine. (2022). *Half-Cut Solar Panels: Pros & Cons*. <https://solarmagazine.com/solar-panels/half-cut-solar-panels/>
- Wikipedia contributors. (2025). *Monocrystalline silicon*. In *Wikipedia*. https://en.wikipedia.org/wiki/Monocrystalline_silicon
- Yuen, S. (2024). Indonesia to add 5.75 GW rooftop solar PV between 2024 and 2028. *PV-Tech*. <https://www.pv-tech.org/indonesia-to-add-5-75gw-rooftop-solar-pv-between-2024-and-2028/>